

## Series 8016 – .075" x .130" x .150" Grid Pattern

### FEATURES

- Available in five sizes: 20, 38, 56, 90 and 120 contacts
- Insertable / removable Varilok contacts
- Crimp, solder, solderless wrap, and taper tab terminations
- Exceptional versatility: all hardware can be mounted on plug or receptacle (see ordering code)
- Actuating screw facilitates mating and unmating, locks mated connectors together
- Polarizing hardware can be set to any of six positions at factory; can also be reset by user (see polarizing code)
- Optional cover with top or side cable entry and clamp
- Optional cable strain relief clamp with adjustable strap for large or small cable bundles (fits on sizes 38 and 56)
- Plug and receptacle contacts are protected from mishandling
- Guide pins and sockets ensure correct alignment when mating
- U.L. recognized polyester material
- Aluminum covers
- CSA acceptable polyester material



### CABLE STRAIN RELIEF CLAMP

- Adjustable for large or small cable bundles
- Versatile clamp assembly permits mounting in various directions. Can be mounted on plug and/or receptacle.
- Order Number 30-8026-9601 for plug and cable-to-cable applications
- Order Number 30-8026-9602 for receptacle applications
- Available for sizes 38 and 56

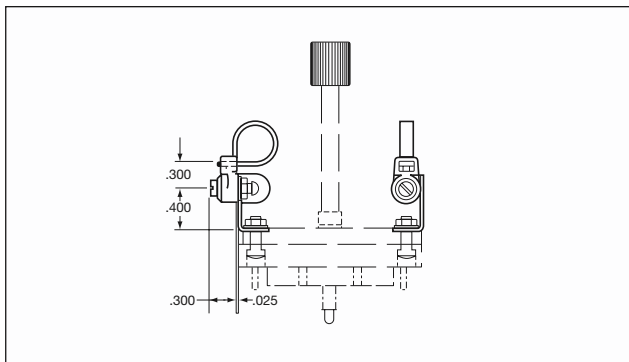

### TECHNICAL SPECIFICATIONS

**Current Rating:**

8 amperes, maximum

**Contact Resistance:**

6 milliohms, maximum

**Contact Material:**

Phosphor bronze

**Contact Plating:**

Gold, 10 microinches min.,  
over Nickel,  
50-100 microinches

**Insulator Material:**

Thermoplastic 94V-O glass  
filled polyester

**Insulation Resistance:**

5,000 megohms, min.  
(polyester)

Sea Level: 1250 volts RMS

3.4" Hg: 625 volts RMS

**Cover and Clamp Material and Finish:**

Aluminum with clear chromate under grey  
enamel finish

**Commercial Specification:**

Covered under the components recognition  
program of Underwriters' Laboratory,  
Inc. File No. E-27610

### CONNECTORS:

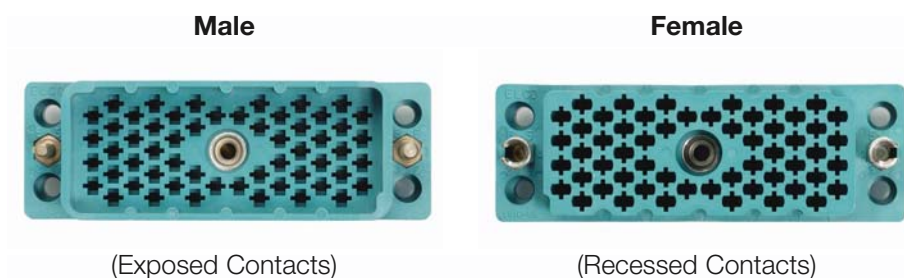

### COVERS:



### CONTACTS:



## Series 8016 – Rectangular Connector – 20 Contact

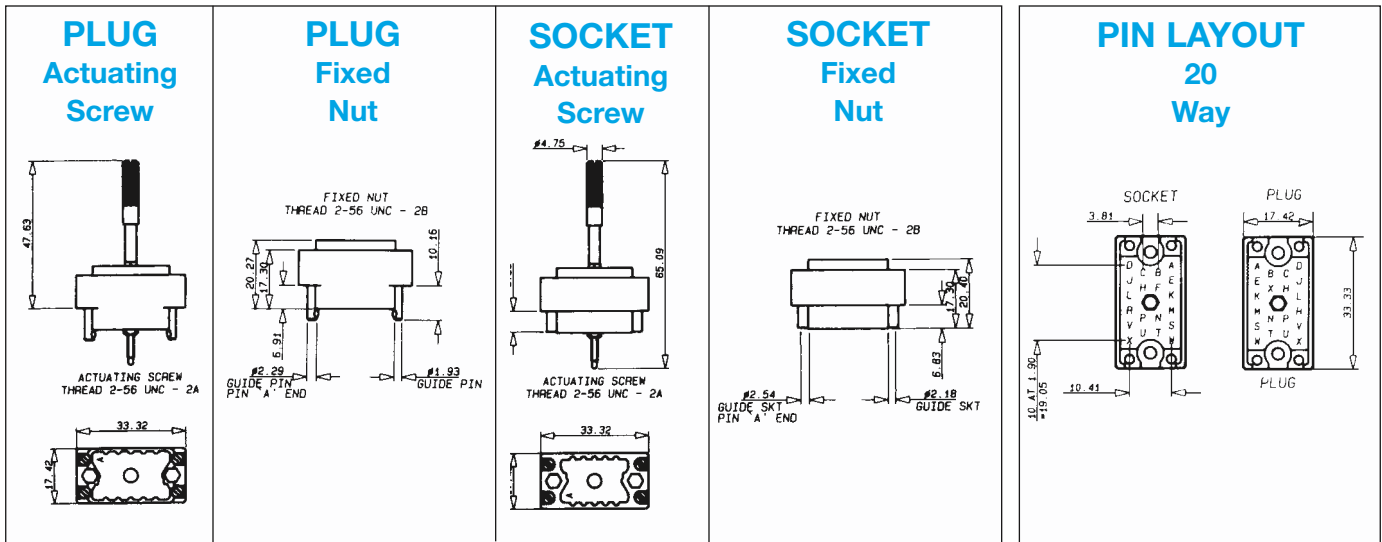

### ORDERING CODE



**Contact Termination**

\*000 = Contacts not fitted and ordered separately, see page 23 for full list of options

217 = Solder 0.098" x 2.49mm

218 = Wire Wrap –   
 0.025 x 0.050 x 0.567" / 0.64 x 1.27 x 14.4mm

296 = Wire Wrap –   
 0.025 x 0.026 x 0.579" / 0.64 x 1.27 x 19.3mm

504 = Solder Tail –

750 = Wire Wrap –   
 0.025 x 0.050 x 0.760" / 0.64 x 1.27 x 19.3mm

\*Crimp contacts always ordered separately. See page 25 for details.

### RECOMMENDED LAYOUT FOR FRONT CHASSIS MOUNTING & PCB LAYOUT

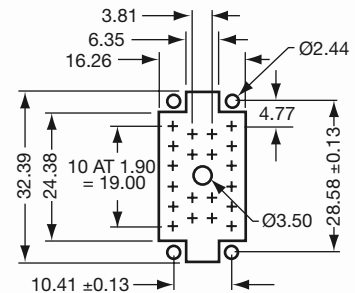

See page 26 for assembly tools.

20 CONTACTS					COVER			
Insulator Body Type	Basic P/N*	Color	Thread	No Cover	Top Std Clamp	Side Std Clamp	Actuating Screw	Fixed Nut
Male	00 8016 020 000 XXX	Green	UNC	601	603	604	Y	N
Male	00 8016 020 000 XXX	Green	UNC	602	605	606	N	Y
Male	00 8016 020 000 XXX	Gray	Metric	001	903	904	Y	N
Male	00 8016 020 000 XXX	Gray	Metric	002	905	906	N	Y
Female	00 8016 020 000 XXX	Green	UNC	607	609	610	N	Y
Female	00 8016 020 000 XXX	Green	UNC	608	611	612	Y	N
Female	00 8016 020 000 XXX	Gray	Metric	007	909	910	N	Y
Female	00 8016 020 000 XXX	Gray	Metric	008	911	912	Y	N

\*Select the column desired and replace the XXX with the numbers from column.

## Series 8016 – Rectangular Connector – 38 Contact

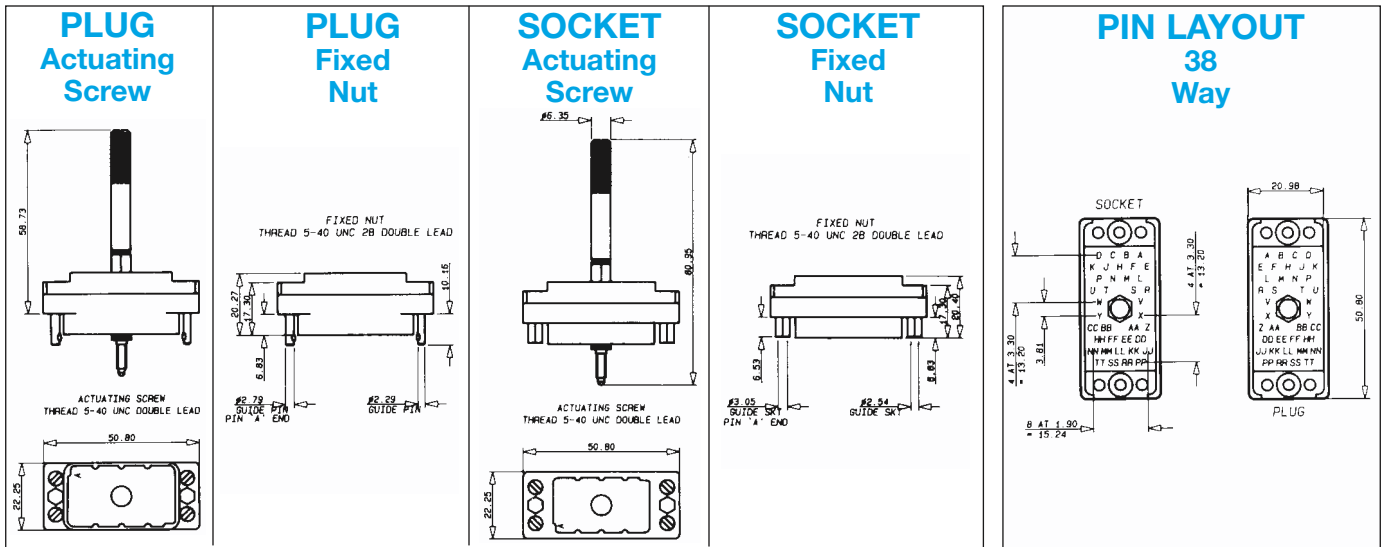

### ORDERING CODE



Contact Termination	
*000 = Contacts not fitted and ordered separately, see page 23 for full list of options	
217 = Solder 0.098" x 2.49mm	
218 = Wire Wrap - 0.025 x 0.050 x 0.567" / 0.64 x 1.27 x 14.4mm	
296 = Wire Wrap - 0.025 x 0.026 x 0.579" / 0.64 x 1.27 x 19.3mm	
504 = Solder Tail -	
750 = Wire Wrap - 0.025 x 0.050 x 0.760" / 0.64 x 1.27 x 19.3mm	

\*Crimp contacts always ordered separately. See page 25 for details.

### RECOMMENDED LAYOUT FOR FRONT CHASSIS MOUNTING & PCB LAYOUT

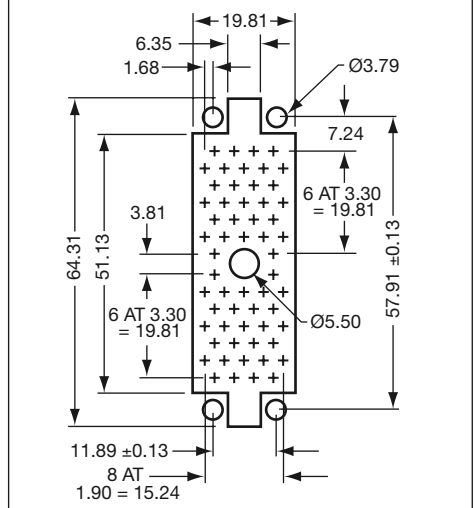

See page 26 for assembly tools.

38 CONTACTS					COVER								Actuating Screw	Fixed Nut
Insulator Body Type	Basic P/N*	Color	Thread	No Cover	Top Std Clamp	Side Std Clamp	Top Lge Clamp	Side Lge Clamp	Top EX Lge Clamp	Top EX Lge Clamp				
Male	00 8016 038 000 XXX	Green	UNC	601	603	604	619	620	631	632	Y	N		
Male	00 8016 038 000 XXX	Green	UNC	602	605	606	621	622	633	634	N	Y		
Male	00 8016 038 000 XXX	Gray	Metric	001	903	904	919	920	931	932	Y	N		
Male	00 8016 038 000 XXX	Gray	Metric	002	905	906	921	922	933	934	N	Y		
Female	00 8016 038 000 XXX	Green	UNC	607	609	610	623	624	635	636	N	Y		
Female	00 8016 038 000 XXX	Green	UNC	608	611	612	625	626	637	638	Y	N		
Female	00 8016 038 000 XXX	Gray	Metric	007	909	910	923	924	935	936	N	Y		
Female	00 8016 038 000 XXX	Gray	Metric	008	911	912	925	926	937	938	Y	N		

\*Select the column desired and replace the XXX with the numbers from column.

## Series 8016 – Rectangular Connector – 56 Contact

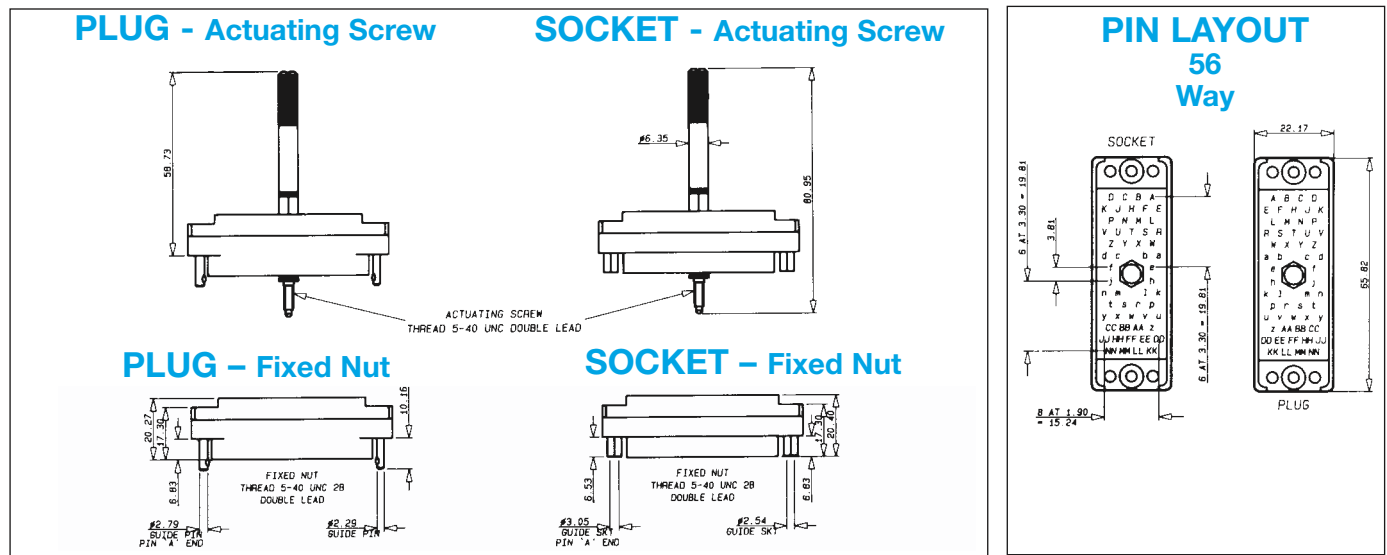

### ORDERING CODE

**00**      **8016**      **056**      **217**      **601**

Prefix      Series Number      Number of Contacts      See table below

Contact Termination	
*000 =	Contacts not fitted and ordered separately, see page 23 for full list of options
217 =	Solder 0.098" x 2.49mm
218 =	Wire Wrap – 0.025 x 0.050 x 0.567" / 0.64 x 1.27 x 14.4mm
296 =	Wire Wrap – 0.025 x 0.026 x 0.579" / 0.64 x 1.27 x 19.3mm
504 =	Solder Tail –
750 =	Wire Wrap – 0.025 x 0.050 x 0.760" / 0.64 x 1.27 x 19.3mm

\*Crimp contacts always ordered separately. See page 25 for details.

### RECOMMENDED LAYOUT FOR FRONT CHASSIS MOUNTING & PCB LAYOUT

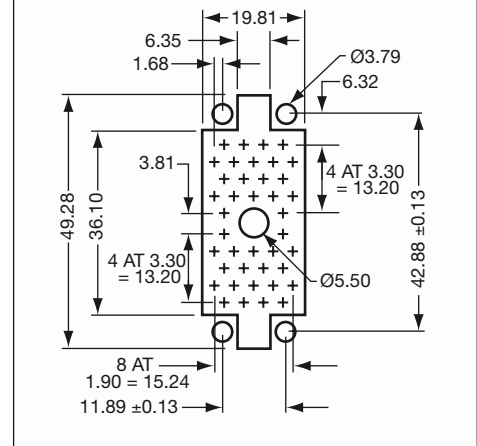

See page 26 for assembly tools.

56 CONTACTS					COVER							Actuating Screw	Fixed Nut
Insulator Body Type	Basic P/N*	Color	Thread	No Cover	Top Std Clamp	Side Std Clamp	Top Lge Clamp	Side Lge Clamp	Top EX Lge Clamp	Top EX Lge Clamp			
Male	00 8016 056 000 XXX	Green	UNC	601	603	604	619	620	631	632	Y	N	
Male	00 8016 056 000 XXX	Green	UNC	602	605	606	621	622	633	634	N	Y	
Male	00 8016 056 000 XXX	Gray	Metric	001	903	904	919	920	931	932	Y	N	
Male	00 8016 056 000 XXX	Gray	Metric	002	905	906	921	922	933	934	N	Y	
Female	00 8016 056 000 XXX	Green	UNC	607	609	610	623	624	635	636	N	Y	
Female	00 8016 056 000 XXX	Green	UNC	608	611	612	625	626	637	638	Y	N	
Female	00 8016 056 000 XXX	Gray	Metric	007	909	910	923	924	935	936	N	Y	
Female	00 8016 056 000 XXX	Gray	Metric	008	911	912	925	926	937	938	Y	N	

\*Select the column desired and replace the XXX with the numbers from column.

## Series 8016 – Rectangular Connector – 90 Contact

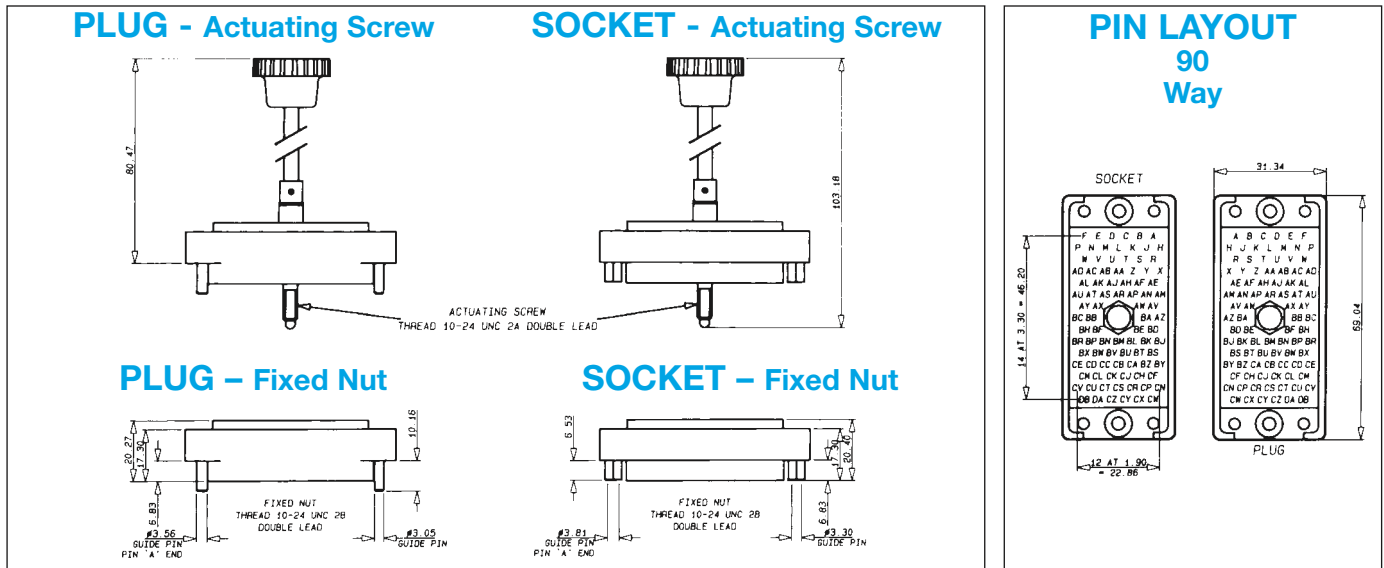

### ORDERING CODE



**Contact Termination**

\*000 = Contacts not fitted and ordered separately, see page 23 for full list of options

217 = Solder 0.098" x 2.49mm

218 = Wire Wrap –   
0.025 x 0.050 x 0.567" / 0.64 x 1.27 x 14.4mm

296 = Wire Wrap –   
0.025 x 0.026 x 0.579" / 0.64 x 1.27 x 19.3mm

504 = Solder Tail –

750 = Wire Wrap –   
0.025 x 0.050 x 0.760" / 0.64 x 1.27 x 19.3mm

\*Crimp contacts always ordered separately. See page 25 for details.

### RECOMMENDED LAYOUT FOR FRONT CHASSIS MOUNTING & PCB LAYOUT

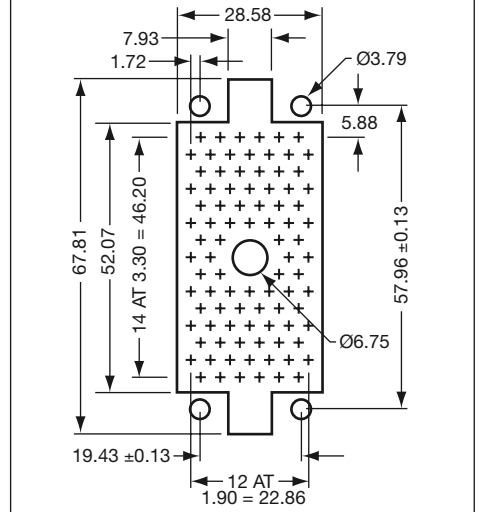

See page 26 for assembly tools.

90 CONTACTS					COVER				Actuating Screw	Fixed Nut
Insulator Body Type	Basic P/N*	Color	Thread	No Cover	Top Lge Clamp	Side Lge Clamp	Top EX Lge Clamp	Top EX Lge Clamp		
Male	00 8016 090 000 XXX	Green	UNC	601	603	604	631	632	Y	N
Male	00 8016 090 000 XXX	Green	UNC	602	605	606	633	634	N	Y
Male	00 8016 090 000 XXX	Gray	Metric	001	903	904	931	932	Y	N
Male	00 8016 090 000 XXX	Gray	Metric	002	905	906	933	934	N	Y
Female	00 8016 090 000 XXX	Green	UNC	607	609	610	635	636	N	Y
Female	00 8016 090 000 XXX	Green	UNC	608	611	612	637	638	Y	N
Female	00 8016 090 000 XXX	Gray	Metric	007	909	910	935	936	N	Y
Female	00 8016 090 000 XXX	Gray	Metric	008	911	912	937	938	Y	N

\*Select the column desired and replace the XXX with the numbers from column.

## Series 8016 – Rectangular Connector – 120 Contact

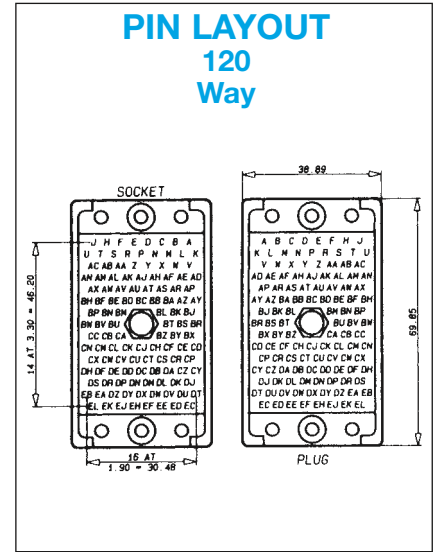
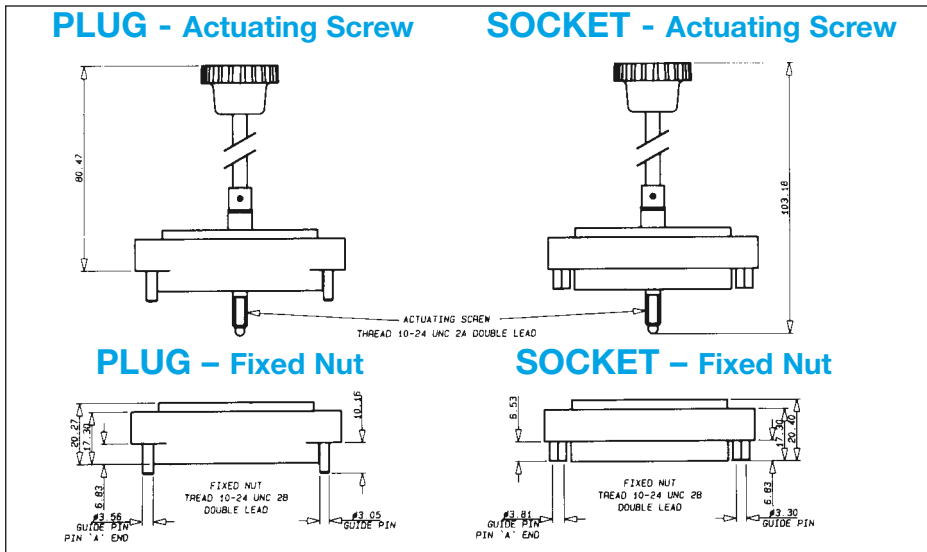

### ORDERING CODE



**Contact Termination**

- \*000 = Contacts not fitted and ordered separately, see page 23 for full list of options
- 217 = Solder 0.098" x 2.49mm
- 218 = Wire Wrap – 0.025 x 0.050 x 0.567" / 0.64 x 1.27 x 14.4mm
- 296 = Wire Wrap – 0.025 x 0.026 x 0.579" / 0.64 x 1.27 x 19.3mm
- 504 = Solder Tail –
- 750 = Wire Wrap – 0.025 x 0.050 x 0.760" / 0.64 x 1.27 x 19.3mm

\*Crimp contacts always ordered separately. See page 25 for details.

### RECOMMENDED LAYOUT FOR FRONT CHASSIS MOUNTING & PCB LAYOUT

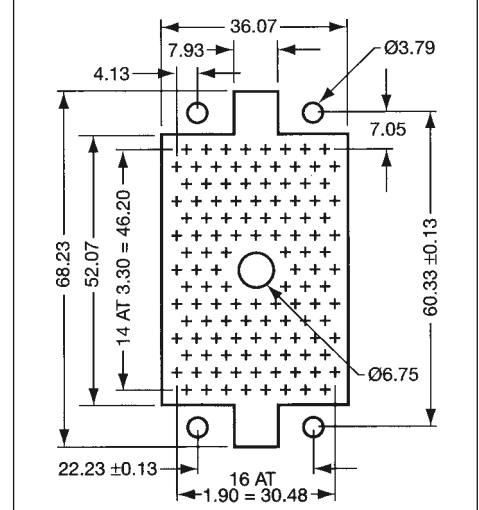

See page 26 for assembly tools.

120 CONTACTS					COVER				Actuating Screw	Fixed Nut
Insulator Body Type	Basic P/N*	Color	Thread	No Cover	Top Lge Clamp	Side Lge Clamp	Top EX Lge Clamp	Top EX Lge Clamp		
Male	00 8016 120 000 XXX	Green	UNC	601	603	604	631	632	Y	N
Male	00 8016 120 000 XXX	Green	UNC	602	605	606	633	634	N	Y
Male	00 8016 120 000 XXX	Gray	Metric	001	903	904	931	932	Y	N
Male	00 8016 120 000 XXX	Gray	Metric	002	905	906	933	934	N	Y
Female	00 8016 120 000 XXX	Green	UNC	607	609	610	635	636	N	Y
Female	00 8016 120 000 XXX	Green	UNC	608	611	612	637	638	Y	N
Female	00 8016 120 000 XXX	Gray	Metric	007	909	910	935	936	N	Y
Female	00 8016 120 000 XXX	Gray	Metric	008	911	912	937	938	Y	N

\*Select the column desired and replace the XXX with the numbers from column.

## Series 8016 Covers

Part Number	For Size	Hardware Threads	Cable Entance	Clamp Type	Size mm (inches)
30 8016 9829 00 000	20	UNC	Side	Standard	11.53 (0.454) Dia
30 8016 9831 00 000	20	UNC	Top	Standard	11.53 (0.454) Dia
30 8016 9829 20 000	20	Metric	Side	Standard	11.53 (0.454) Dia
30 8016 9831 20 000	20	Metric	Top	Standard	11.53 (0.454) Dia
30 8016 0200 00 413	20	UNC	Side/Top	Standard	5 x 10 (0.197 x 0.394) min
30 8016 0200 00 413	20	UNC	45	Standard	5 x 10 (0.197 x 0.394) min
30 8016 9821 00 000	38	UNC	Side	Standard	16.51 x 12.70 (0.650 x 0.500)
30 8016 9822 00 000	38	UNC	Top	Standard	16.51 x 12.70 (0.650 x 0.500)
30 8016 9825 00 000	38	UNC	Side	Large	16.51 x 15.44 (0.650 x 0.608)
30 8016 9826 00 000	38	UNC	Top	Large	16.51 x 15.44 (0.650 x 0.608)
30 8016 9838 00 000	38	UNC	Side	Ex-Large	20.83 x 15.60 (0.820 x 0.614)
30 8016 9839 00 000	38	UNC	Top	Ex-Large	20.83 x 15.60 (0.820 x 0.614)
30 8016 9821 20 000	38	Metric	Side	Standard	16.51 x 12.70 (0.650 x 0.500)
30 8016 9822 20 000	38	Metric	Top	Standard	16.51 x 12.70 (0.650 x 0.500)
30 8016 9825 20 000	38	Metric	Side	Large	16.51 x 15.44 (0.650 x 0.608)
30 8016 9826 20 000	38	Metric	Top	Large	16.51 x 15.44 (0.650 x 0.608)
30 8016 9838 20 000	38	Metric	Side	Ex-Large	20.83 x 15.60 (0.820 x 0.614)
30 8016 9839 20 000	38	Metric	Top	Ex-Large	20.83 x 15.60 (0.820 x 0.614)
30 8016 0380 00 413	38	UNC	Top/Side	Standard	6 x 14 (0.236 x 0.551) min
30 8016 0380 00 415	38	UNC	45	Standard	6 x 14 (0.236 x 0.551) min
30 8016 9823 00 000	56	UNC	Side	Standard	16.51 x 12.70 (0.650 x 0.500)
30 8016 9824 00 000	56	UNC	Top	Standard	16.51 x 12.70 (0.650 x 0.500)
30 8016 9827 00 000	56	UNC	Side	Large	16.51 x 15.44 (0.650 x 0.608)
30 8016 9828 00 000	56	UNC	Top	Large	16.51 x 15.44 (0.650 x 0.608)
30 8016 9840 00 000	56	UNC	Side	Ex-Large	20.83 x 15.60 (0.820 x 0.614)
30 8016 9842 00 000	56	UNC	Top	Ex-Large	20.83 x 15.60 (0.820 x 0.614)
30 8016 9823 20 000	56	Metric	Side	Standard	16.51 x 12.70 (0.650 x 0.500)
30 8016 9824 20 000	56	Metric	Top	Standard	16.51 x 12.70 (0.650 x 0.500)
30 8016 9827 20 000	56	Metric	Side	Large	16.51 x 15.44 (0.650 x 0.608)
30 8016 9828 20 000	56	Metric	Top	Large	16.51 x 15.44 (0.650 x 0.608)
30 8016 9840 20 000	56	Metric	Side	Ex-Large	20.83 x 15.60 (0.820 x 0.614)
30 8016 9842 20 000	56	Metric	Top	Ex-Large	20.83 x 15.60 (0.820 x 0.614)
30 8016 0560 00 413	56	UNC	Top/Side	Standard	6 x 14 (0.236 x 0.551) min
30 8016 0560 00 415	56	UNC	45	Standard	6 x 14 (0.236 x 0.551) min
30 8016 9832 00 000	90	UNC	Side	Large	20.32 (0.800) Dia
30 8016 9833 00 000	90	UNC	Top	Large	20.32 (0.800) Dia
30 8016 9843 00 000	90	UNC	Side	Ex-Large	25.40 x 20.32 (1.00 x 0.800)
30 8016 9844 00 000	90	UNC	Top	Ex-Large	25.40 x 20.32 (1.00 x 0.800)
30 8016 9832 20 000	90	Metric	Side	Large	20.32 (0.800) Dia
30 8016 9833 20 000	90	Metric	Top	Large	20.32 (0.800) Dia
30 8016 9843 20 000	90	Metric	Side	Ex-Large	25.40 x 20.32 (1.00 x 0.800)
30 8016 9844 20 000	90	Metric	Top	Ex-Large	25.40 x 20.32 (1.00 x 0.800)
30 8016 9834 00 000	120	UNC	Side	Large	20.32 x 27.43 (0.800 x 1.080)
30 8016 9835 00 000	120	UNC	Top	Large	20.32 x 27.43 (0.800 x 1.080)
30 8016 9845 00 000	120	UNC	Side	Ex-Large	27.94 x 27.56 (1.100 x 1.085)
30 8016 9846 00 000	120	UNC	Top	Ex-Large	27.94 x 27.56 (1.100 x 1.085)
30 8016 9834 20 000	120	Metric	Side	Large	20.32 x 27.43 (0.800 x 1.080)
30 8016 9835 20 000	120	Metric	Top	Large	20.32 x 27.43 (0.800 x 1.080)
30 8016 9845 20 000	120	Metric	Side	Ex-Large	27.94 x 27.56 (1.100 x 1.085)
30 8016 9846 20 000	120	Metric	Top	Ex-Large	27.94 x 27.56 (1.100 x 1.085)



## Series 8016 Covers

### CLAMPING AND COVER DIMENSIONS    OPTIONAL REMOVABLE SIDE PLATE COVER 20 CONTACTS

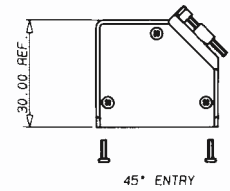
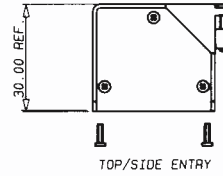
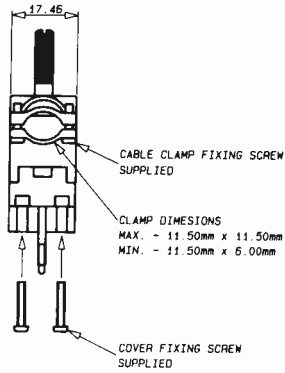
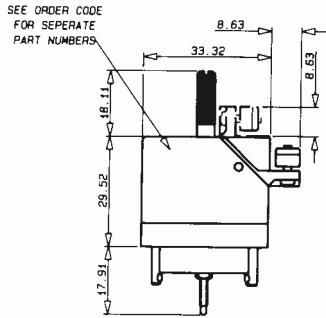

CLAMP	
<b>Minimum Size</b>	
5 x 10 (0.197 x 0.394)	
5 x 10 (0.197 x 0.394)	
<b>Maximum Size</b>	
10 x 10 (0.394 x 0.394)	
10 x 10 (0.394 x 0.394)	

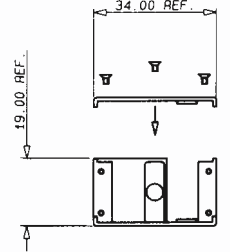

### 38 CONTACTS

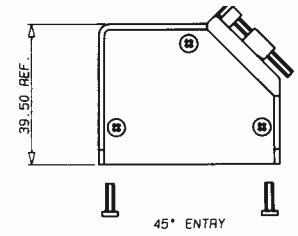
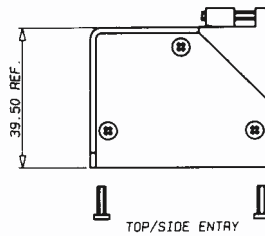
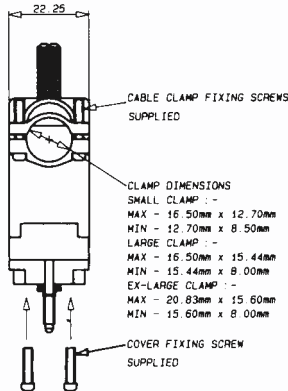
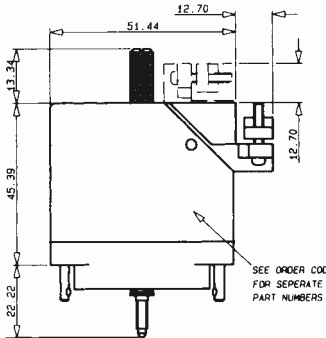

CLAMP	
<b>Minimum Size</b>	
6 x 14 (0.236 x 0.551)	
6 x 14 (0.236 x 0.551)	
<b>Maximum Size</b>	
17 x 14 (0.669 x 0.551)	
17 x 14 (0.669 x 0.551)	

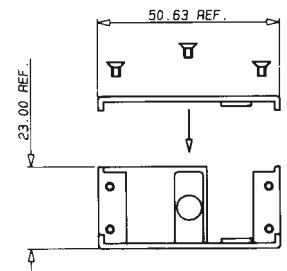

### 56 CONTACTS

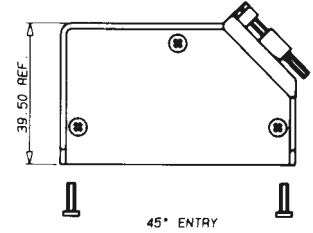
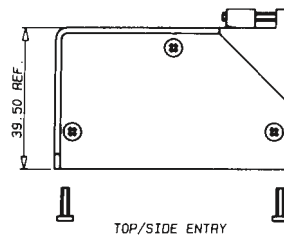
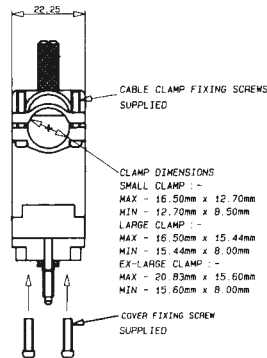
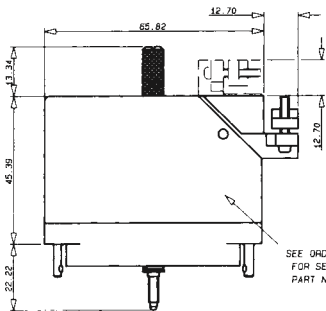

CLAMP	
<b>Minimum Size</b>	
6 x 14 (0.236 x 0.551)	
6 x 14 (0.236 x 0.551)	
<b>Maximum Size</b>	
17 x 14 (0.669 x 0.551)	
17 x 14 (0.669 x 0.551)	

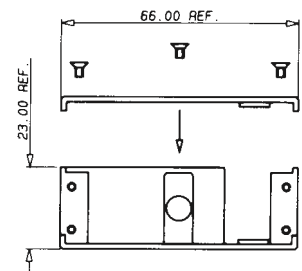

See page 21 for part numbers

### CLAMPING AND COVER DIMENSIONS

#### 90 CONTACTS

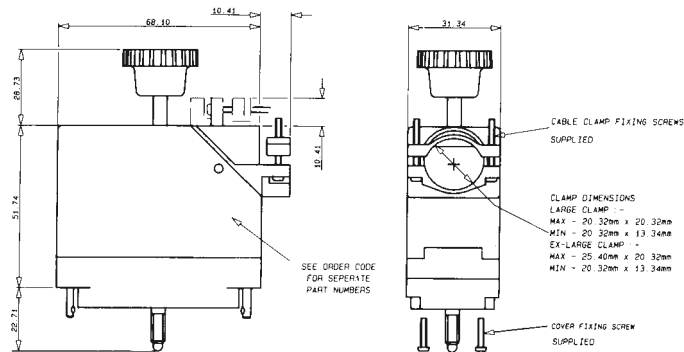

#### 120 CONTACTS

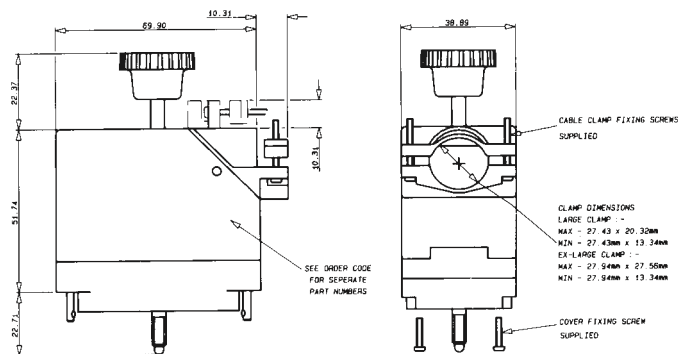

See page 21 for part numbers